

# SCHEDA TECNICA DIMENSIONALE DEL PRODOTTO

## DIMENSIONI LINGOTTO

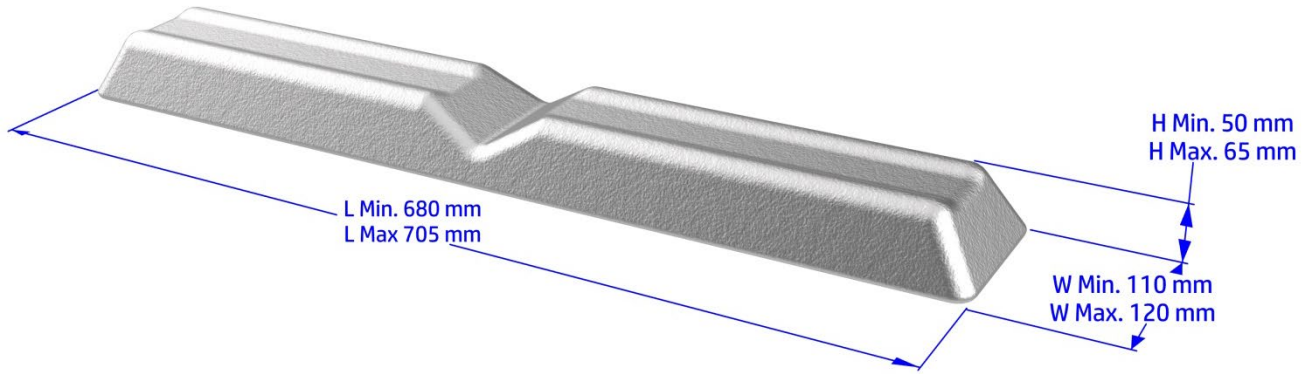

Peso minimo medio: 7 Kg  
Peso massimo medio: 9 Kg

### CATASTA STANDARD N°1

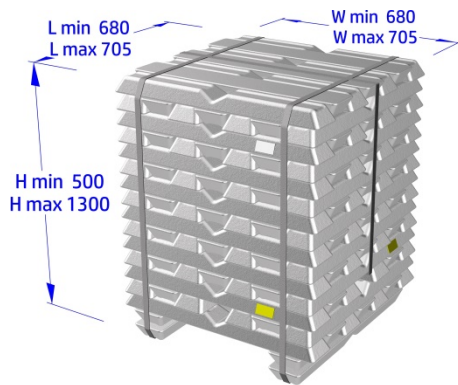

Peso minimo medio: 420 Kg  
Peso massimo medio: 1170 Kg

#### Particolare dimensioni pallet

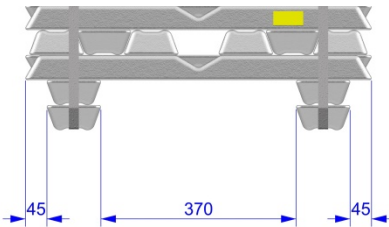

### CATASTA STANDARD N°2

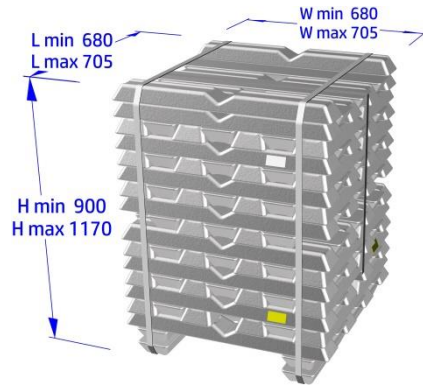

Peso minimo medio: 760 Kg  
Peso massimo medio: 980 Kg

#### Particolare dimensioni pallet

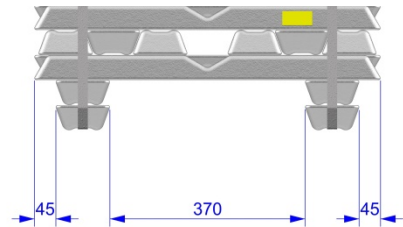

# SCHEDA TECNICA DIMENSIONALE DEL PRODOTTO

## CATASTA STANDARD N°3

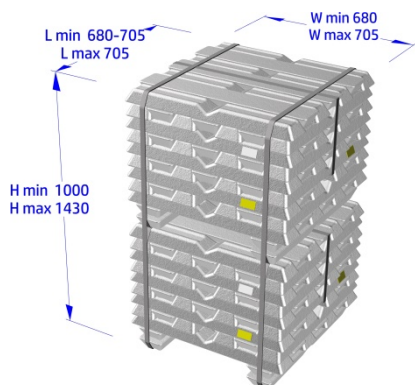

Peso minimo medio: 840 Kg  
Peso massimo medio: 1200Kg

### Particolare dimensioni pallet

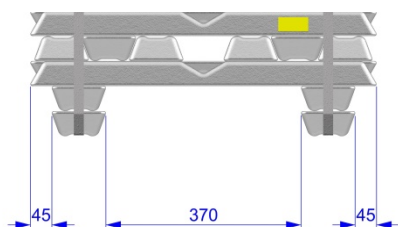

## CATASTA STANDARD N°4

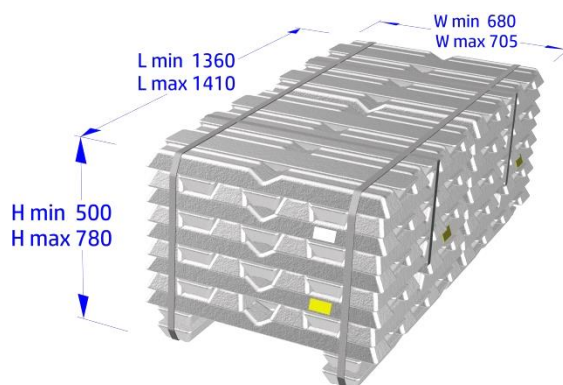

Peso minimo medio: 840 Kg  
Peso massimo medio: 1330 Kg

### Particolare dimensioni pallet

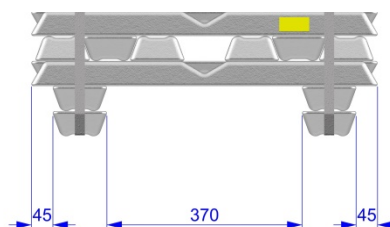

## CATASTA STANDARD N°5

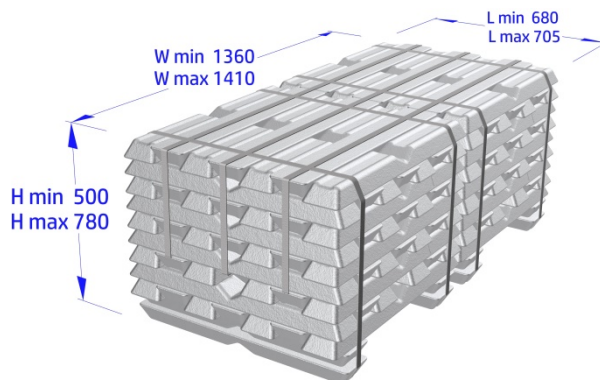

Peso minimo medio: 840 Kg  
Peso massimo medio: 1330 Kg

### Particolare dimensioni pallet

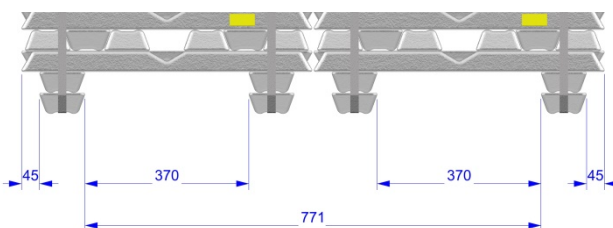

\* EVENTUALI VARIAZIONI SULLE CONFIGURAZIONI DELLE CATASTE POSSONO ESSERE CONCORDATE CON IL CLIENTE

**S.A.V. S.p.A.**  
**Società Alluminio Veneto**

SEDE LEGALE:  
VIA COLOMBO, 5, 35010 TREBASELEGHE (PD) ITALY  
TELEFONO: +39 049 9386191 FAX 049 9387828;  
E-MAIL : [info@sav-al.com](mailto:info@sav-al.com) WEB: [www.sav-al.com](http://www.sav-al.com)

COMPANY WITH  
MANAGEMENT SYSTEM  
CERTIFIED  
= ISO 14001 =  
= ISO 45001 =  
= ISO 50001 =

VERIFIED ENVIRONMENTAL  
MANAGEMENT  
**EMAS**  
IT-00184

COMPANY WITH  
MANAGEMENT SYSTEM  
CERTIFIED  
= ISO 9001 =  
= IATF 16949 =

